

Hose Reel User Manual

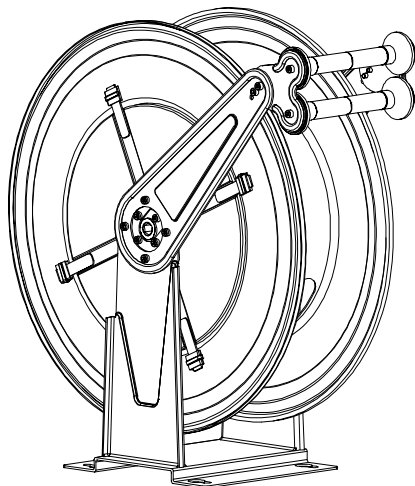

Box Contents

Hose Reel - With or without hose
Swivel Joint - Usually fitted to the reel
Printed Mounting Template
Hose Bumper Stop

Optional Extras (Ordered separately)

Hose - Fitted to reel
Connection Hose
Guns/Nozzles
Mounting Brackets

No tools are supplied with this product

Basic Safety

DO NOT UNDER ANY CIRCUMSTANCES DISMANTLE THE SPRING CASSETTE OR DRUM

The cassette holds the spring which is under a great deal of tension which if released can cause serious injury.

This hose reel features moving parts that can cause injuries, particularly to hands. Please take extreme care when performing any of the procedures in the manual. This symbol is present where there is a greater risk.

Take appropriate precautions against fire and explosions if using fuel or hazardous particles are present in the environment.

If in any doubt contact your dealer.



Hose Reel Breakdown

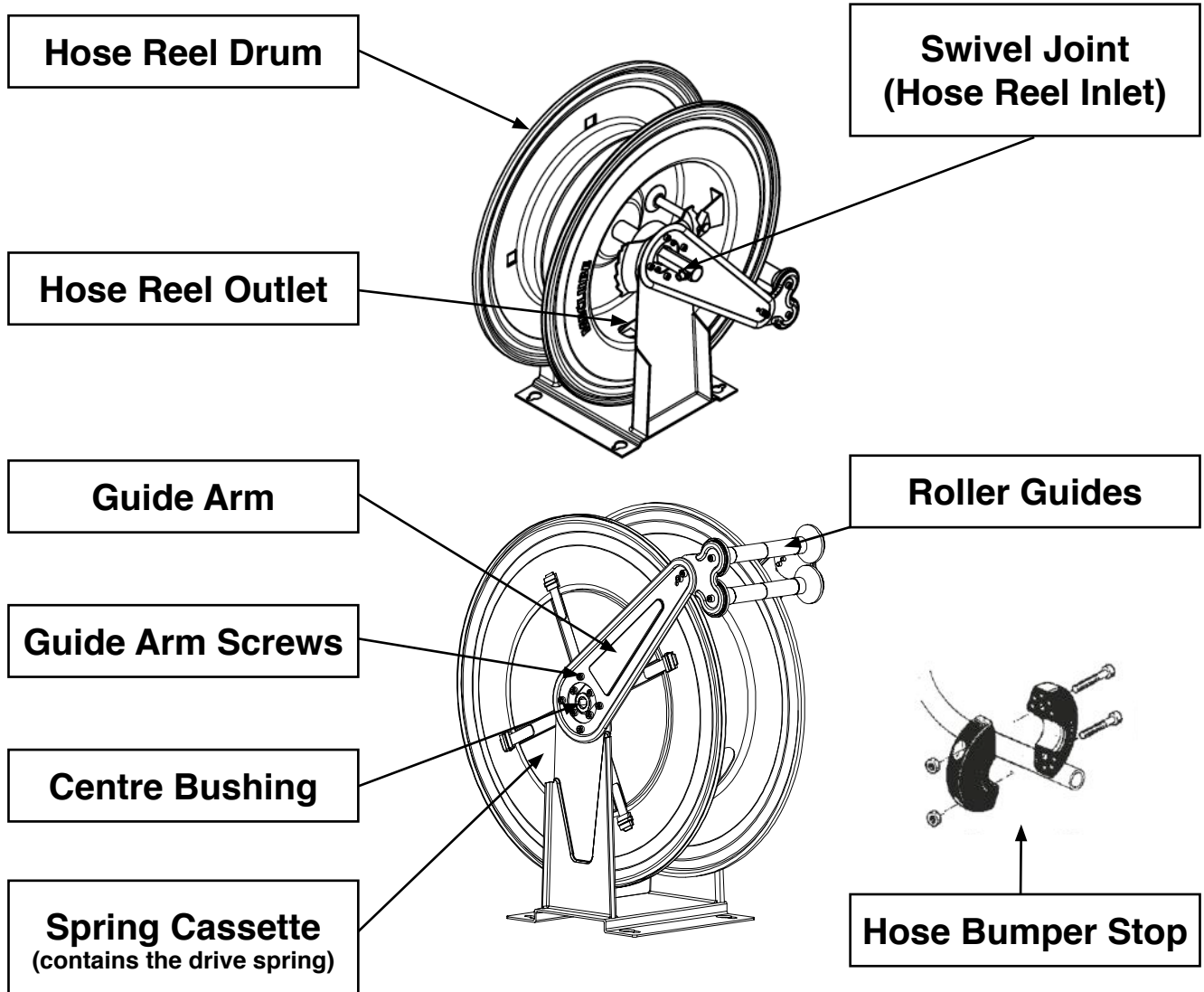

Weights & Dimensions

All weights are without hose

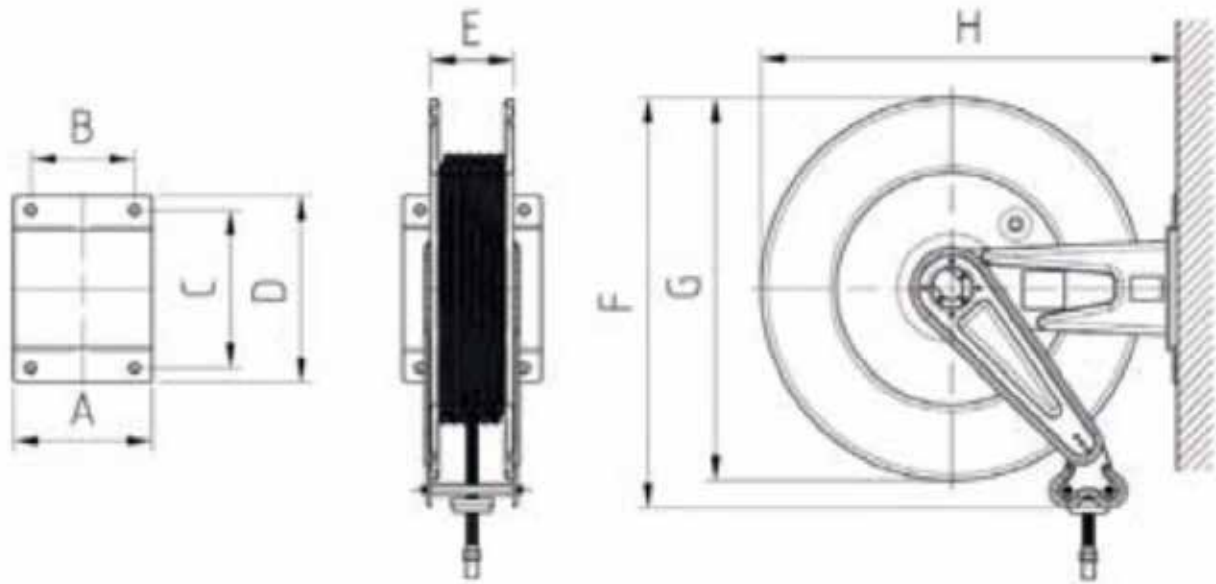

Series	A	B	C	D	E	F	G	H	Weight (KG)
F400	158	120	168	192	95	450	400	435	12.5
F460	158	120	168	192	95	480	460	500	16.6
F550	200	150	225	270	120	590	550	600	22
F555	250	200	225	270	170	590	550	600	26
F560	440	390	225	270	360	590	550	600	33

Hose Capacity

How much hose you can fit is determined by the internal drive spring and O.D (Outside diameter) of your hose.

Series	Hose O.D.	Hose Capacity
F400 & FX400	14mm	20m
	16mm	18m
	19.5mm	12m
F460 & FX460	17mm	21m
	19.5mm	16m
	22mm	14m
F550 & FX550	18.5mm	28m
	20mm	26m
	22mm	24m

Series	Hose O.D.	Hose Capacity
F555 & FX555	22mm	30m
	28mm	22m
	34mm	17m
F560 & FX560	22mm	60m
	30mm	40m
	35mm	30m

Hose Fitting - (Go to next section if your reel already has hose fitted)

Before you start

You will need; 5mm hex wrench (Allen Key)
14mm hex wrench (Allen key)
Adjustable spanner



Make sure the reel is in a secure position, this can be mounted in place or secured to a workbench.



The hose being fitted must have a pressure rating equal to or higher than the operating pressure of the hose reel.

1. Make sure the reel is unlatched and there is no spring tension on the reel.

2. If you need an adapter or bush to connect the hose to the reel outlet, fit it now.



3. Feed your hose onto the drum and connect to the hose reel outlet with your spanner.



4. Carefully turn the drum by hand to wind on all of your hose.



"If you have space we recommend uncoiling all of your hose and laying in a straight line before winding onto the drum."



5. Pull 30 to 50cm of hose through the roller guides and fit the hose bumper.

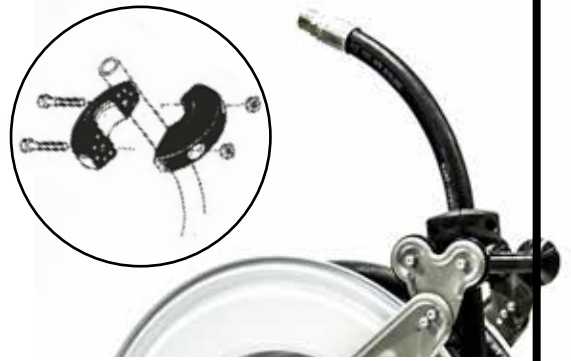

If your hose connection wont fit through the roller guide, loosen the screws on the side of the roller guide. Re-tighten once the hose is pulled through.



6. Using the 5mm hex wrench, remove the screws (3 or 4 depending on model) that hold the 14mm centre bushing in place.



7. Using your 14mm hex wrench turn the centre bushing anticlockwise;
*3x complete turns for 3/8" & 1/2" hose
or
4x complete turns for 3/4" and 1" hose*
Re-insert the screws and tighten.



8. Test your reel - There should be just enough tension to return the hose. If more tension is required repeat steps 6. & 7.



Do not put more than a total of 5 pre-turns. This will over tension the spring and can cause it to snap.

Installation

MOUNTING

Make sure the wall, ceiling or floor is strong enough to hold the weight of the reel during operation

Weights can be found in the front of this manual

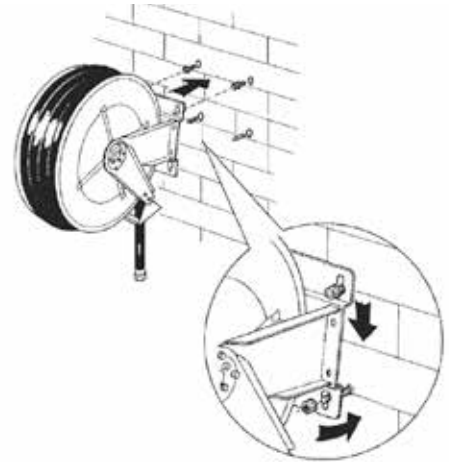

Setup Your Guide Arm

The guide arm needs to be set to provide the least resistance when the hose is pulled out.

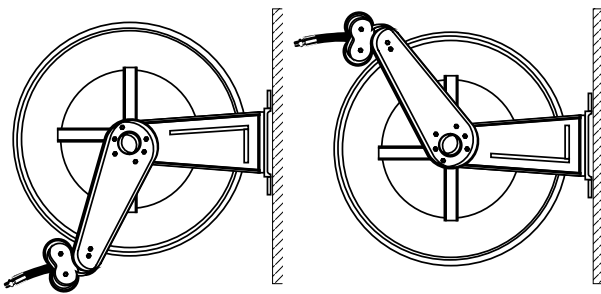

Wall Mounted below 2metres

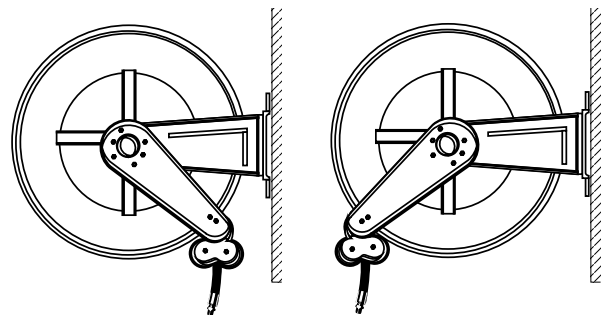

Wall Mounted above 2metres

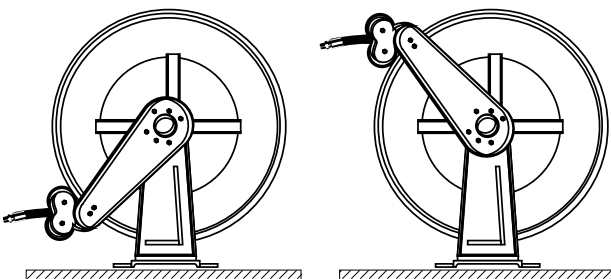

Floor Mounted

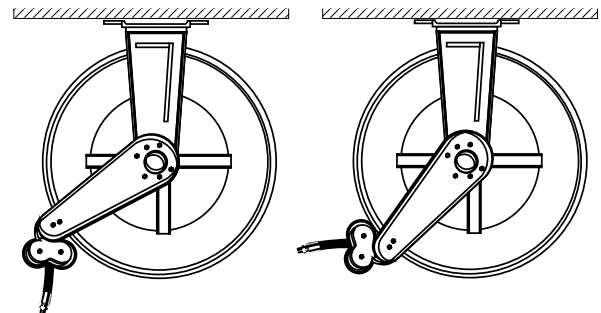

Ceiling Mounted

Underbench Mounted

Because of the weight of the hose pulling down it is not recommended to install the reel above 4metres

Guide Arm Adjustment

You will need; 5mm hex wench (Allen key)



1. Hold the hose firmly in place and undo the guide arm screws on both sides



Tension will still be on the reel. Proceed with caution.



2. Reposition the guide arm in the correct position and re-tighten all the guide arm screws.

3. Adjust the roller guides to provide the best position for the hose to be pulled out.



Flexible Connection Pipe

A flexible pipe must be used to connect the supply to the swivel joint - This reduces wear to the O-Ring seals in the swivel and allows the spring to engage correctly.



Failure to use a flexible pipe dramatically reduces hose reel life and will void your warranty.

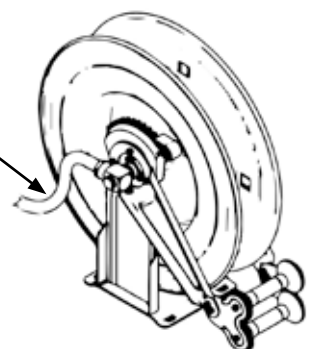

Hose Replacement

You will need; Adjustable spanner



Make sure the reel is in a secure position, this can be mounted in place or secured to a workbench

1. Some fluid will remain in the hose so take precautions for spillages.

2. Pull all of the hose off the reel and secure the reel on the latch.

If your hose end connection wont fit through the roller guide, loosen the screws on the side of the roller guide. Re-tighten once the hose is pulled through.



3. CAREFULLY disconnect the hose.



Do not under any circumstances take the drum off the latch



4. Connect your new hose securely and release from the latch

How To Use Your Hose Reel Correctly

1. Hold only the hose when pulling out the hose.



Pulling out the hose holding the tool or hose bumper can considerably shorten the hose life.

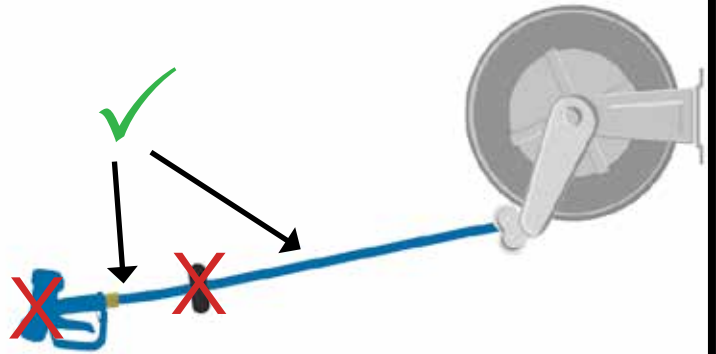

2. Pull the hose to the right length and the latch will lock the hose in place.

You can hear the latch click when it is engaged



3. Crack on with the job



4. To release the latch hold the hose firmly and gently pull towards you until the latch is released.



5. **DO NOT LET GO OF THE HOSE**

Still holding the hose, walk the hose back onto the reel

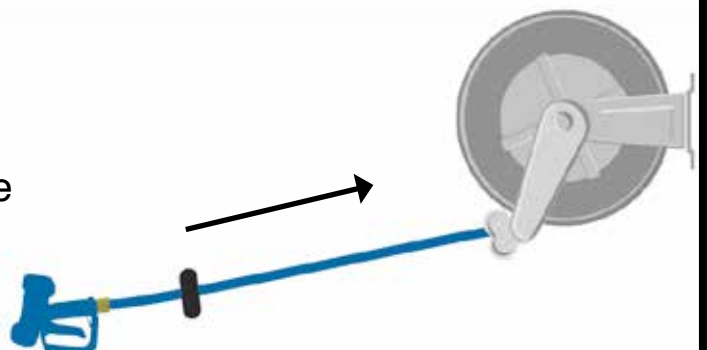

Trouble Shooting

THE SWIVEL IS LEAKING

There could be several reasons for your hose reel swivel to leak.

'O' Ring: The "O" ring is worn or the wrong "O" ring is being used for the material being handled. The 'O' ring will need to be replaced. Please get in touch with your model number

Loose Swivel: The swivel assembly maybe loose or not enough thread sealant has been used on the shaft threads. Apply more thread sealant and re-tighten the swivel assembly.

Cracked Swivel: Extremely cold conditions can sometimes cause the swivel assembly to crack. Inspect the swivel for any hair-line cracks.

Pressure: More pressure is being applied to the reel than the recommended pressure of the hose reel. If possible lower the pressure or call us so we can advise on how best to remedy the problem as the procedure may change depending on model.

Solid Inlet Pipe: If a flexible connection to the hose reel is not used, you will cause excessive binding to the main shaft and hub bearings causing the reel not to retract, or create possible leaking, this will also void any warranty.

MY HOSE REEL WILL NOT RETRACT

There could be several reasons for your hose reel not retracting.

Height: If the reel is mounted above 4 metres (17ft) the drive spring may not have enough strength to retract the weight of the hose. You will need to reduce the height of the mounted reel or contact customer services with your model and serial numbers of the reel so we can advise on how best to remedy the problem as the procedure may change depending on model.

Spring Tension: There is insufficient spring tension. Please contact customer services with your model and serial numbers of the reel so we can advise on how best to re-tension the reel and remedy the problem as the procedure can change depending on model.

Latch: The latch is engaged with the drive spring coiled tight. This is called lockout and only happens on some reels. If problem continues, contact customer services with your model and serial numbers of the reel so we can advise on how best to remedy the problem as the procedure can change depending on model.

Solid Inlet Pipe: If the reel has been connected in solid piping you will cause excessive binding to the main shaft and hub bearings causing the reel not to retract or create possible leaking. Disconnect the inlet pipe to see if the problems continues.

Mounting: Bolting the reel down to an uneven surface could distort the frame causing a bind on the main support shafts restricting smooth retraction of hose.

REEL WON'T LOCK IN PLACE PROPERLY

Broken Latch: This could mean there is a broken latch spring, a bent latch pawl or latch plate. Inspect the latch pawl and teeth. The broken part(s) will need to be replaced. Please contact customer services with your model and serial number of the reel so we can advise on how best to remedy the problem as the procedure may change depending on model.

Operator Training

Almost all faults are caused by misuse from the operator. We strongly recommend training staff with the safe use of your hose reel stressing the following point;

“ALWAYS WALK THE HOSE BACK ONTO THE REEL.”

Warranty // Damage

We have a robust system to test whether damage is caused by incorrect operation and no liability will be accepted if we find misuse a factor in warranty claims

hosereels
DIRECT.NET

